

INSTRUCTIONS

RD12 + V-1230RH

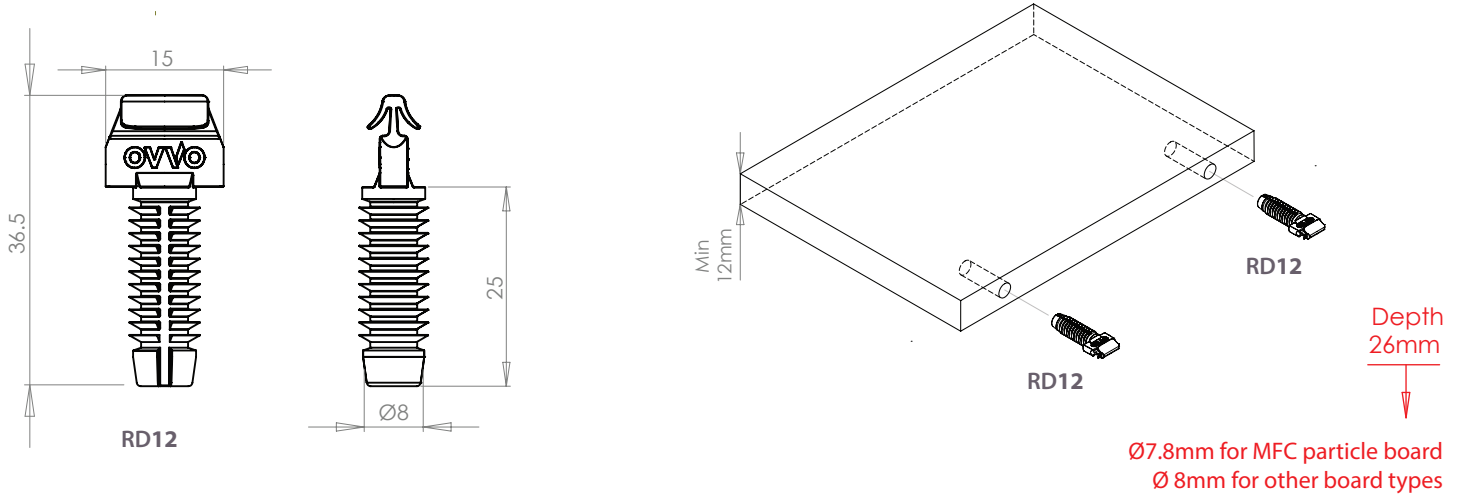

1. Drilling for RD12



2. Milling for V-1230RH

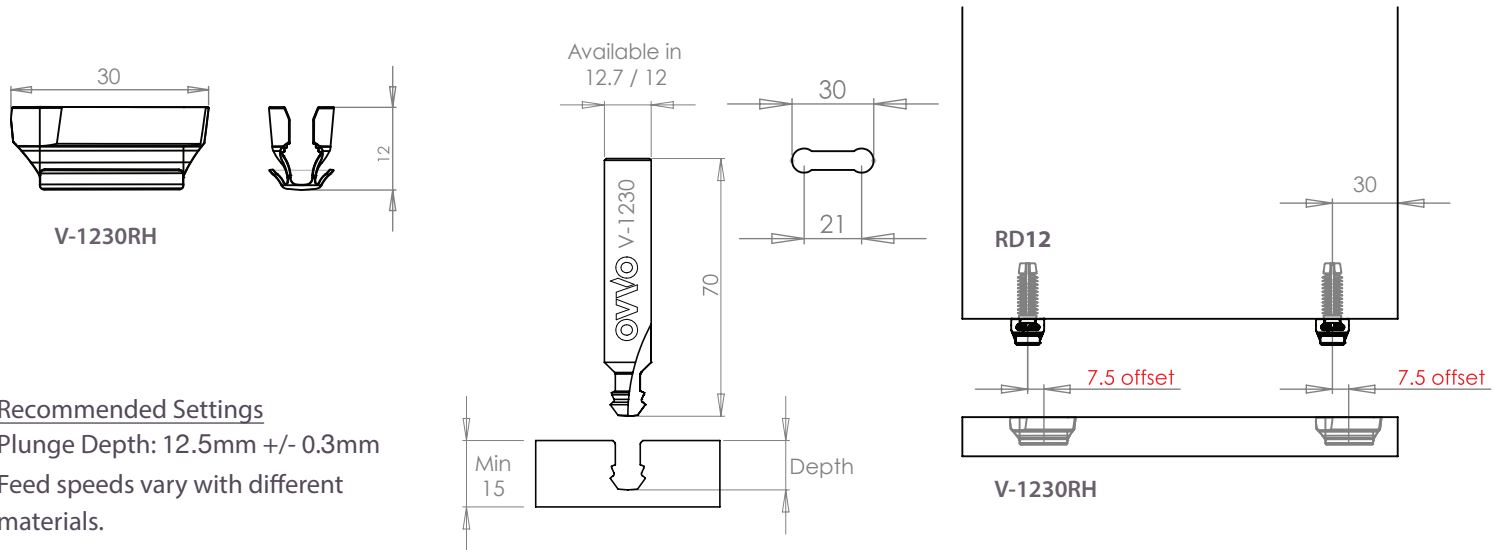

Recommended Settings
 Plunge Depth: 12.5mm +/- 0.3mm
 Feed speeds vary with different materials.

3. Assembly

